

# Install / Use & Care MANUAL

## **5 SERIES**

Professional Undercounter Wine Cellar

VWUI5241

# CONTENTS

## Contents:

Safety information .....	2
Unpacking your appliance .....	3
Warranty registration .....	3
Installing your appliance .....	4
Cabinet clearances .....	4
Leveling the appliance .....	4
Electrical connection .....	5
Door reversal .....	6
Product dimensions .....	7
Using your Electronic control .....	9
Shelving configurations .....	11
Care and cleaning .....	12
Energy saving tips .....	12
Service Information.....	13
Troubleshooting .....	14
Warranty .....	15

## Important Safety Instructions

Warnings and safety instructions appearing in this guide are not meant to cover all possible conditions and situations that may occur. Common sense, caution, and care must be exercised when installing, maintaining, or operating this appliance.

### Recognize Safety Symbols, Words, and Labels.



#### WARNING

**WARNING** - You can be killed or seriously injured if you do not follow these instructions.



#### CAUTION

**CAUTION**-Hazards or unsafe practices which could result in personal injury or property / product damage.

#### NOTE

**NOTE**-Important information to help assure a problem free installation and operation.



#### WARNING

**State of California Proposition 65 Warning:**  
This product contains one or more chemicals known to the State of California to cause cancer.



#### WARNING

**State of California Proposition 65 Warning:**  
This product contains one or more chemicals known to the State of California to cause birth defects or other reproductive harm..



#### WARNING

**WARNING** -This unit contains R600a (Isobutane) which is a flammable hydrocarbon. It is safe for regular use. Do not use sharp objects to expedite defrosting. Do not damage refrigerant circuit.

# UNPACKING YOUR APPLIANCE



## WARNING

### EXCESSIVE WEIGHT HAZARD

Use two or more people to move product.  
Failure to do so can result in personal injury.

### Remove Interior Packaging

Your appliance has been packed for shipment with all parts that could be damaged by movement securely fastened. Remove internal packing materials and any tape holding internal components in place. The owners manual is shipped inside the product in a plastic bag along with the warranty registration card, and other accessory items.

### Important

Keep your carton and packaging until your appliance has been thoroughly inspected and found to be in good condition. If there is damage, the packaging will be needed as proof of damage in transit. Afterwards please dispose of all items responsibly.



## WARNING

**WARNING** - Dispose of the plastic bags which can be a suffocation hazard.

### Note to Customer

This merchandise was carefully packed and thoroughly inspected before leaving our plant. Responsibility for its safe delivery was assumed by the retailer upon acceptance of the shipment. Claims for loss or damage sustained in transit must be made to the retailer.

## NOTE

DO NOT RETURN DAMAGED MERCHANDISE TO THE MANUFACTURER - FILE THE CLAIM WITH THE RETAILER.



## CAUTION

If the appliance was shipped, handled, or stored in other than an upright position for any period of time, allow the appliance to sit upright for a period of at least 24 hours before plugging in. This will assure oil returns to the compressor. Plugging the appliance in immediately may cause damage to internal parts.

### Warranty Registration

It is important you send in your warranty registration card immediately after taking delivery of your appliance or you can register online at [www.vikingrange.com](http://www.vikingrange.com) in the US or [brigade.ca](http://brigade.ca) in Canada.

The following information will be required when registering your appliance.

Service Number

Serial Number

Date of Purchase

Dealer's name and address

Online registration  
available at  
[www.vikingrange.com](http://www.vikingrange.com) in  
the US or  
[brigade.ca](http://brigade.ca) in Canada

The service number and serial number can be found on the serial plate which is located inside the cabinet on the left side near the top. See figure 1.

VIKING RANGE, LLC	
GREENWOOD, MS 38930	
MODEL NO.	<input type="text"/>
SERIAL NO.	<input type="text" value="XXXXXXXXXXXX"/>
HZ <input type="text"/>	VOLTS <input type="text"/>
AMPS <input type="text"/>	R134A <input type="text"/> oz
TEST PRESSURE 140 PSI LOW SIDE 300 PSI HIGH SIDE	

Figure 1



## WARNING

### WARNING - Help Prevent Tragedies

Child entrapment and suffocation are not problems of the past. Junked or abandoned refrigerators are still dangerous - even if they sit out for "just a few hours".

If you are getting rid of your old refrigerator, please follow the instructions below to help prevent accidents.

Before you throw away your old refrigerator or freezer:

- Take off the doors or remove the drawers.
- Leave the shelves in place so children may not easily climb inside.

# INSTALLING YOUR APPLIANCE

## Select Location

The proper location will ensure peak performance of your appliance. We recommend a location where the unit will be out of direct sunlight and away from heat sources. To ensure your product performs to specifications, the recommended installation location temperature range is from 55 to 100°F (13 to 38°C).

## Cabinet Clearance

Ventilation is required from the bottom front of the appliance. Keep this area open and clear of any obstructions. Adjacent cabinets and counter top can be installed around the appliance as long as the front grille remains unobstructed. All Professional models with articulated hinges are intended for built-in applications only.

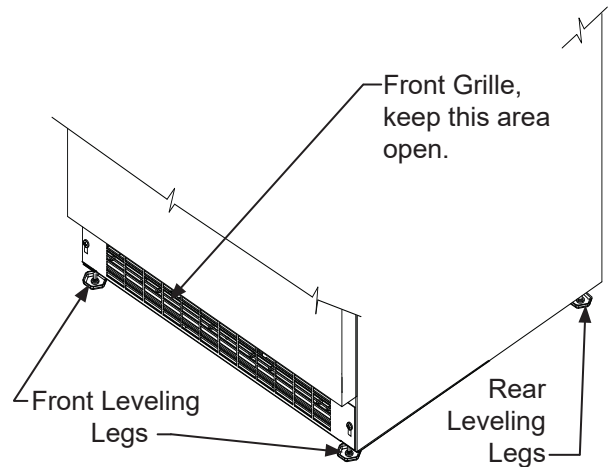

Figure 2

## Leveling Legs

Adjustable legs at the front and rear corners of the appliance should be set so the unit is firmly positioned on the floor and level from side to side and front to back. The overall height of your appliance may be adjusted higher (by turning the leveling leg out, CCW) and lower (by turning the leveling leg in, CW) dimensions as shown in Table "A".

To adjust the leveling legs, place the appliance on a solid surface and protect the floor beneath the legs to avoid scratching the floor. With the assistance of another person, lean the appliance back to access the front leveling legs. Raise or lower the legs to the required dimension by turning the legs. Repeat this process for the rear by tilting the appliance forward using caution. On a level surface check the appliance for levelness and adjust accordingly.

The front grille screws may be loosened and the grille adjusted to the desired height. When adjustment is complete tighten the two front grille screws. (See Figure 5).



## Front Grille

Do not obstruct the front grille. The openings within the front grille allow air to flow through the condenser heat exchanger. Restrictions to this air flow will result in increased energy usage and loss of cooling capacity. For this reason it is important this area to not be obstructed and the grille openings kept clean. Viking Range, LLC does not recommend the use of a custom made grille as air flow may be restricted. (See Figure 2).

Model	Door Style	Minimum Height	Maximum Height
VWUI5241	(G)	33 ¾" (85.7 cm)	34 ¾" (88.3 cm)

Table A

## INSTALLING YOUR APPLIANCE

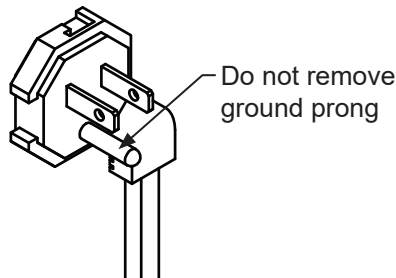

Figure 3

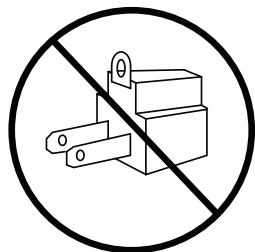

Figure 4

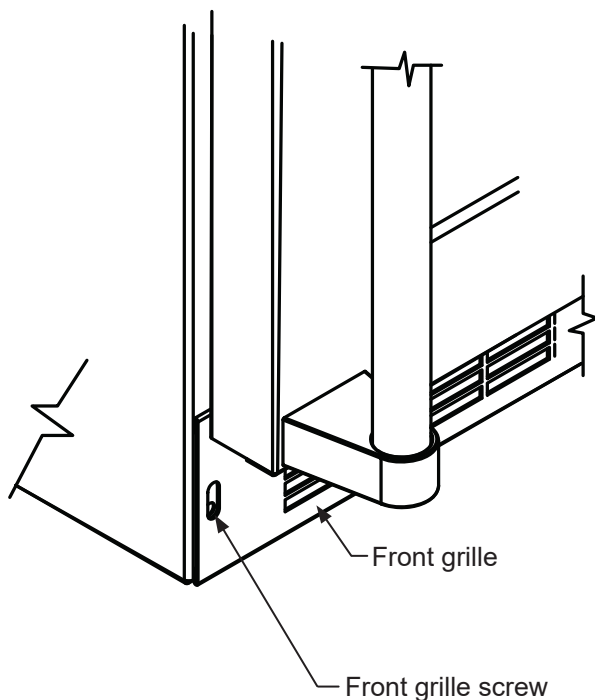

Figure 5

### WARNING

#### Electrical Shock Hazard

- Do not use an extension cord with this appliance. They can be hazardous and can degrade product performance.
- This appliance should not, under any circumstances, be installed to an un-grounded electrical supply.
- Do not remove the grounding prong from the power cord. (See Figure 3).
- Do not use an adapter. (See Figure 4).
- Do not splash or spray water from a hose on the appliance. Doing so may cause an electrical shock, which may result in severe injury or death.

#### Electrical Connection

A grounded 115 volt, 15 amp dedicated circuit is required.

This product is factory equipped with a power supply cord that has a three-pronged, grounded plug. It must be plugged into a mating grounding type receptacle in accordance with the National Electrical Code and applicable local codes and ordinances (see Figure 6). If the circuit does not have a grounding type receptacle, it is the responsibility and obligation of the customer to provide the proper power supply. The third ground prong should not, under any circumstances, be cut or removed.

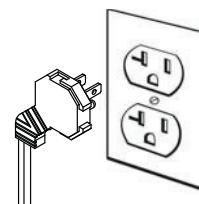

Figure 6

### NOTE

Ground Fault Circuit Interrupters (GFCI) are prone to nuisance tripping which will cause the appliance to shut down. GFCI's are generally not used on circuits with power equipment that must run unattended for long periods of time, unless required to meet local building codes and ordinances.

# DOOR REVERSAL

## Door Reversing Instructions

1. Open door.
2. Loosen screw #1 and #2 using a Philips Screwdriver on top and bottom hinge. Slide door and remove the door from the unit.

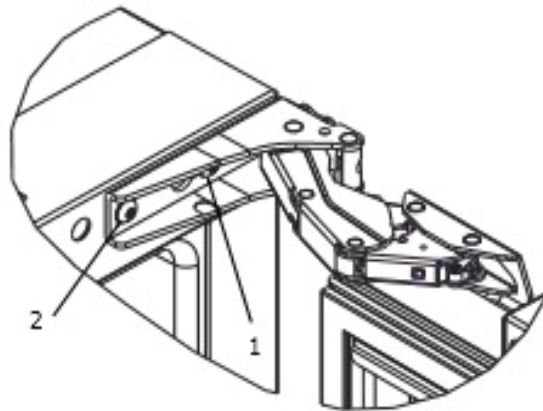

Figure 7

3. Once door is removed, using a Philips Screwdriver remove screws from magnet actuator located on inside and bottom of door. (On Integrated Models magnet actuator will be located on bottom of door.)



Figure 8

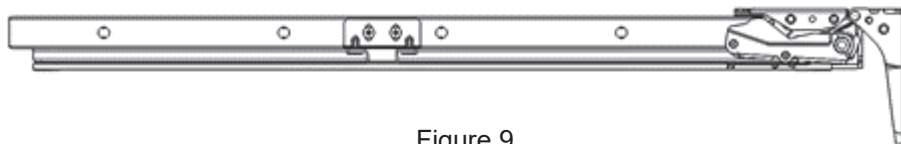

Figure 9

4. Remove caps from top of door. Using a Philips Screwdriver, install magnet actuator on opposite side. Install caps into opposite side.
5. Remove caps from screw holes on opposite side (2 on top and bottom). Using a Philips Screwdriver remove the 4 screws that you previously loosened.
6. Reinstall screws and caps on opposite side.
7. Once screws are partially installed, rotate the door 180°, align the hinge over screw #1 and slide into position. Tighten screws on top and bottom.
8. Door is now reversed.

# PRODUCT DIMENSIONS

MODEL	ROUGH-IN OPENING DIMENSIONS			CABINET DIMENSIONS					
	"A"	"B"	"C"	"D"	"E"	"F"	"G"	"H"	"J"
VWUI5241	24" (61 cm)	**34" to 35" (86.4 to 88.9 cm)	*	23 <sup>7</sup> / <sub>8</sub> " (60.7cm)	33 <sup>3</sup> / <sub>4</sub> " to 34 <sup>3</sup> / <sub>4</sub> " (85.7 to 88.3 cm)	23 <sup>23</sup> / <sub>32</sub> " (60.2 cm)	26 <sup>7</sup> / <sub>32</sub> " (66.6 cm)	46 <sup>13</sup> / <sub>32</sub> " (117.9 cm)	26 <sup>7</sup> / <sub>16</sub> " (67.2 cm)

\* Depth dimension of rough-in opening may vary depending on each individual installation. To recess entire door "F" dimension plus 1" (2.5 cm) for thickness of power cord plug is required.

\*\* Minimum rough-in opening required is to be larger than the adjusted height of the cabinet.

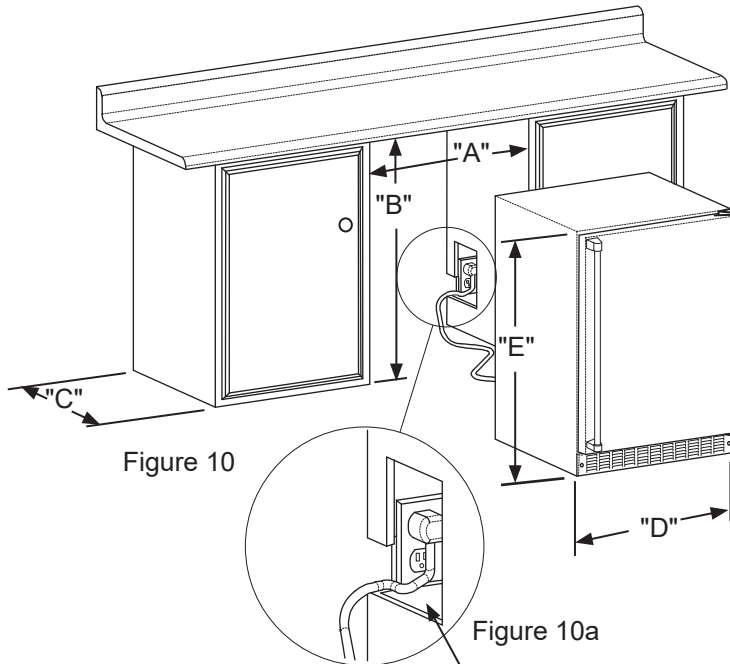

Figure 10

Figure 10a

If necessary to gain clearance inside the rough-in opening a hole can be cut through the adjacent cabinet and the power cord routed through this hole to a power outlet. Another way to increase the available opening depth is to recess the power outlet into the rear wall to gain the thickness of the power cord plug. Not all recessed outlet boxes will work for this application as they are too narrow, but a recessed outlet box equivalent to Arlington #DVFR1W is recommended for this application, (see Figure 11).



Figure 11

# PRODUCT DIMENSIONS

PRODUCT DATA		
MODEL	ELECTRICAL REQUIREMENTS #	PRODUCT WEIGHT
VWU15241	115V/60HZ/15A	140 lbs (63.6 kg)

# A grounded 15 amp dedicated circuit is required. Follow all local building codes when installing electrical and appliance.

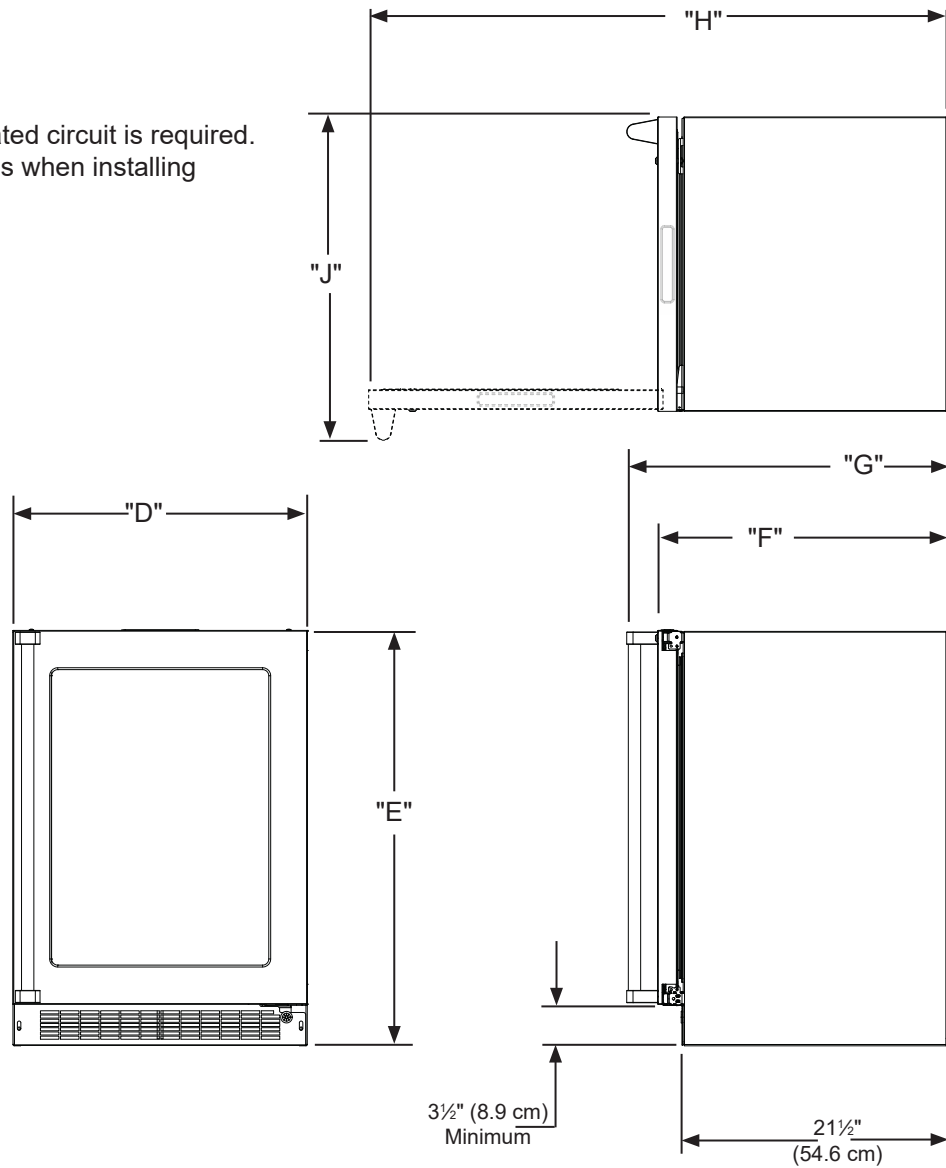
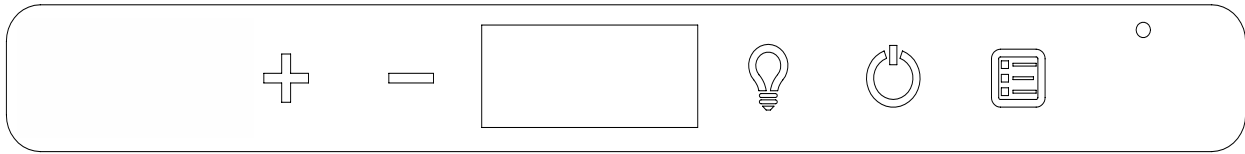

Figure 12



# USING YOUR ELECTRONIC CONTROL



## Control Function Guide

Function	Command	Notes												
ON/OFF	Press  and release.	Unit will immediately turn ON or OFF.												
Adjust Temperatures	Press  or  and release to adjust the upper zone. Press  to change to lower zone.	Interior light color indicates zone temperature being set; Blue = Upper (38° - 65°) White = Lower (38° - 65°) Note: The set temperature of the lower zone can't be colder than the set temperature of the upper zone. Adjusting the set temperature of the upper zone may cause the lower zone to automatically adjust. The lower zone cannot be more than 20° above the set temperature of the upper zone. See table on next page.												
Toggle Between °F / °C	Hold  and  for 5 seconds.	The display will change units.												
Leave Interior Light On	Press  and release to leave interior light on for 12 hours; press again to deactivate.	After 12 hours, factory default is restored; light will turn on when door is open.												
Adjust Light Color	While holding , press and release  to scroll through lighting options.	<table border="1"> <thead> <tr> <th>Option</th> <th>Open Door</th> <th>Closed Door</th> </tr> </thead> <tbody> <tr> <td> 00</td> <td>White</td> <td>White</td> </tr> <tr> <td> 01</td> <td>Blue</td> <td>Blue</td> </tr> <tr> <td> 02</td> <td>White</td> <td>Blue</td> </tr> </tbody> </table> <p>Light will be set at full intensity when door is open, and 50% intensity when door is closed.</p>	Option	Open Door	Closed Door	00	White	White	01	Blue	Blue	02	White	Blue
Option	Open Door	Closed Door												
00	White	White												
01	Blue	Blue												
02	White	Blue												
Enable Sabbath Mode	Press  and hold for 5 seconds and release.	The °F / °C symbol will flash briefly after 5 seconds. Interior light and display will go dark and remain so until user resets mode - unit continues to operate.												
Disable Sabbath Mode	Press  and release.	Display and interior light return to normal operation.												
Showroom Mode	Hold  and  for 5 seconds.	The °F / °C symbol will flash. Display will be lit and interior light will function. <b>Unit will not cool.</b> Repeat command to return to normal operation.												

### Door Alert Notification

When the door is left open for more than 30 minutes:

- A tone will sound for several seconds every minute
- will appear in display
- Close door to silence alert and reset

### High/Low Temp. Notifications

When the compartment temperature exceeds the control setting for an extended amount of time:

- "HH" will appear in display (High Temp)
- "LL" will appear in display (Low Temp)

Contact service dept. for further instructions.

### First Use

Initial startup requires no adjustments. When plugged in, the unit will begin operating under the factory default settings. If the unit was turned off during installation, simply press and the unit will immediately switch on.

To turn the unit off, press .

NOTE: Temperature displayed reflects actual temperature inside unit. If the temperature displayed is different than selected, the unit is progressing towards the selected temperature. Time to reach set point varies based upon ambient temperature, temperature of product loaded, door openings, etc. It is recommended to allow the unit to reach set points before loading.

## USING YOUR ELECTRONIC CONTROL

Dual Zone Temperature Table

Note: The temperature of the lower zone cannot be less than the temperature of the upper zone.

Dual Zone		
Upper Zone: 38° - 65°	Lower Zone: 38° - 65°	
	Minimum	Maximum
38	38	58
39	39	59
40	40	60
41	41	61
42	42	62
43	43	63
44	44	64
45	45	65
46	46	65
47	47	65
48	48	65
49	49	65
50	50	65
51	51	65
52	52	65
53	53	65
54	54	65
55	55	65
56	56	65
57	57	65
58	58	65
59	59	65
60	60	65
61	61	65
62	62	65
63	63	65
64	64	65
65	65	65

## SHELVING CONFIGURATIONS

### Loading Tips and Suggestions

Your appliance is equipped with a cantilever shelf system which provides maximum adjust ability and customizing of the shelving arrangements listed below.

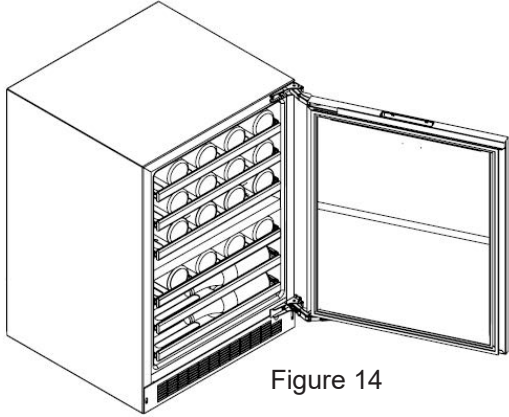

Figure 14

### VWUI5241:

#### 24" (61 cm) Wide Models:

- (5) 8 bottle wire racks
- (2) 4 bottle half-depth wire racks

## CARE AND CLEANING AND ENERGY SAVING TIPS

### Front Grille

Be sure that nothing obstructs the required air flow openings in front of the cabinet. At least once or twice a year, brush or vacuum lint and dirt from the front grille area (see page 4).



**SHOCK HAZARD:** Disconnect electrical power from the appliance before cleaning with soap and water.

### Cabinet

The painted cabinet can be washed with either a mild soap and water and thoroughly rinsed with clear water. NEVER use abrasive scouring cleaners.

### Interior

Wash interior compartment with mild soap and water. Do NOT use an abrasive cleaner, solvent, polish cleaner or undiluted detergent.

### Care of Appliance

1. Avoid leaning on the door, you may bend the door hinges or tip the appliance.
2. Exercise caution when sweeping, vacuuming or mopping near the front of the appliance. Damage to the grille can occur.
3. Periodically clean the interior of the appliance as needed.
4. Periodically check and/or clean the front grille as needed.

### In the Event of a Power Failure

If a power failure occurs, try to correct it as soon as possible. Minimize the number of door openings while the power is off so as not to adversely affect the appliance's temperature.

### Light assembly replacement

All models use an LED to illuminate the interior of the appliance. This component is very reliable, but should it fail, contact a qualified service technician for replacement of the LED.

### The following suggestions will minimize the cost of operating your refrigeration appliance.

1. Do not install your appliance next to a hot appliance (cooker, dishwasher, etc.), heating air duct, or other heat sources.
2. Install product out of direct sunlight.
3. Ensure the front grille vents at front of appliance beneath door are not obstructed and kept clean to allow ventilation for the refrigeration system to expel heat.
4. Plug your appliance into a dedicated power circuit. (Not shared with other appliances).
5. When initially loading your new product, or whenever large quantities of warm contents are placed within refrigerated storage compartment, minimize door openings for the next 12 hours to allow contents to pull down to compartment set temperature.
6. Maintaining a relatively full storage compartment will require less appliance run time than an empty compartment.
7. Ensure door closing is not obstructed by contents stored in your appliance.
8. Allow hot items to reach room temperature before placing in product.
9. Minimize door openings and duration of door openings.
10. Use the warmest temperature control set temperature that meets your personal preference and provides the proper storage for your stored contents.
11. When on vacation or away from home for extended periods, set the appliance to warmest acceptable temperature for the stored contents.
12. Set the control to the "off" position if cleaning the appliance requires the door to be open for an extended period of time.
13. For wine storage products:  
When serving temperatures are not required, return the compartment(s) set temperature to the ideal red and white wine long term storage temperature of 13°C / 55°F.

## SERVICE INFORMATION

If service is required, call your authorized service agency.

Have the following information readily available:

- Model number
- Serial number
- Date purchased
- Name of dealer from whom purchased

Clearly describe the problem that you are having. If you are unable to obtain the name of an authorized service agency, or if you continue to have service problems, contact Viking Range, LLC at (888) 845-4641 or write to:

**VIKING RANGE, LLC  
PREFERRED SERVICE  
111 Front Street  
Greenwood, Mississippi 38930 USA**

Record the information indicated below. You will need it if service is ever required. The serial number and model numbers for your refrigerator are located on the upper wall, behind the lighting:

Model No. \_\_\_\_\_

Serial No. \_\_\_\_\_

Date of Purchase \_\_\_\_\_

Date Installed \_\_\_\_\_

Dealer's Name \_\_\_\_\_

Address \_\_\_\_\_

\_\_\_\_\_

If service requires installation of parts, use only authorized parts to insure protection under the warranty.

**Keep this manual for future reference.**

# TROUBLESHOOTING

## Before You Call for Service

If the appliance appears to be malfunctioning, read through this manual first. If the problem persists, check the troubleshooting guide below. Locate the problem in the guide and refer to the cause and its remedy before calling for service. The problem may be something very simple that can be solved without a service call. However, it may be required to contact your dealer or a qualified service technician.



## CAUTION

In the unlikely event you lose cooling in your unit, **do not unplug the product from the electric supply**, but do call a qualified service technician immediately. It is possible that the loss of cooling capacity is a result of excessive frost build-up on the evaporator cooling coil. In this case, removing power to the unit will result in the melting of this excessive quantity of ice, which could generate melt water that exceeds the capacity of the defrost drain system and could result in water damage to your home. The end-user will be ultimately responsible for any water damage caused by prematurely turning the unit off without appropriately managing the excess water run-off.



## WARNING

### Electrocution Hazard

- Never attempt to repair or perform maintenance on the appliance until the main electrical power has been disconnected. Turning the appliance control "OFF" does not remove electrical power from the units wiring.
- Replace all parts and panels before operating.

Problem	Possible Cause	Remedy
Appliance not cold enough (See "Adjusting the temperature" on page 9)	<ul style="list-style-type: none"> <li>• Control set too warm</li> <li>• Content temperature not stabilized.</li> <li>• Excessive usage or prolonged door openings.</li> <li>• Airflow to front grille blocked.</li> <li>• Door gasket not sealing properly.</li> </ul>	<ul style="list-style-type: none"> <li>• Adjust temperature colder. Allow 24 hours for temperature to stabilize.</li> <li>• Allow temperature to stabilize for at least 24 hours.</li> <li>• Airflow must not be obstructed to front grille. See "clearances" on page 4.</li> <li>• Check door alignment and/or replace door gasket.</li> </ul>
Appliance too cold (See "Adjusting the Temperature" on page 9)	<ul style="list-style-type: none"> <li>• Control set too cold</li> <li>• Door gasket not sealing properly.</li> </ul>	<ul style="list-style-type: none"> <li>• Adjust temperature warmer. Allow 24 hours for temperature to stabilize.</li> <li>• Check door alignment and/or replace door gasket.</li> </ul>
No interior light.	<ul style="list-style-type: none"> <li>• Failed LED light assembly or light switch.</li> </ul>	<ul style="list-style-type: none"> <li>• Contact a qualified service technician.</li> </ul>
Light will not go out when door is closed	<ul style="list-style-type: none"> <li>• Display light is turned on. (Glass door models only.)</li> <li>• Door not activating light switch.</li> <li>• Failed light switch</li> </ul>	<ul style="list-style-type: none"> <li>• Turn off display light, shut door.</li> <li>• Appliance not level, level appliance, (See page 4, "leveling legs")</li> <li>• Contact a qualified service technician.</li> </ul>
Noise or Vibration	<ul style="list-style-type: none"> <li>• Appliance not level</li> <li>• Fan hitting tube obstruction.</li> </ul>	<ul style="list-style-type: none"> <li>• Level appliance, see "Leveling Legs" on page 4.</li> <li>• Contact a qualified service technician.</li> </ul>
Appliance will not run.	<ul style="list-style-type: none"> <li>• Appliance turned off</li> <li>• Power cord not plugged in.</li> <li>• No power at outlet.</li> </ul>	<ul style="list-style-type: none"> <li>• Turn appliance on. See "Starting your appliance" on page 8.</li> <li>• Plug in power cord.</li> <li>• Check house circuit.</li> </ul>

# HOUSEHOLD PRODUCT WARRANTY

## UNDERCOUNTER REFRIGERATOR / BEVERAGE CENTER WARRANTY

### TWO YEAR FULL WARRANTY

Undercounter refrigerators / Beverage Centers and all of their component parts, **except as detailed below\*†**, are warranted to be free from defective materials or workmanship in normal residential use for a period of two (2) years from the date of original retail purchase. Viking Range, LLC, warrantor, agrees to repair or replace, at its option, any part which fails or is found to be defective during the warranty period.

**\*FULL NINETY (90) DAY COSMETIC WARRANTY:** Product is warranted to be free from cosmetic defects in materials or workmanship (such as scratches on stainless steel, paint/porcelain blemishes, etc.) for a period of ninety (90) days from the date of original retail purchase or closing date for new construction, whichever period is longer. Any defects must be reported to the selling dealer within ninety (90) days from date of original retail purchase. Viking Range, LLC uses high quality processes and materials available to produce all color finishes. However, slight color variation may be noticed because of the inherent differences in painted parts and porcelain parts as well as differences in kitchen lighting, product locations, and other factors. Therefore, this warranty does not apply to color variation attributable to such factors.

**†FULL NINETY (90) DAY WARRANTY IN "RESIDENTIAL PLUS" APPLICATIONS:** This full warranty applies to applications where use of the product extends beyond normal residential use, but the warranty period for products used in such applications is ninety (90) days. Examples of applications covered by this warranty are bed and breakfasts, fire stations, private clubs, churches, yachts, etc. Under this "Residential Plus" warranty, the product, its components and accessories are warranted to be free from defective material or workmanship for a period of ninety (90) days from the date of original retail purchase. This warranty excludes use of the product in all commercial locations such as restaurants, food service locations and institutional food service locations.

### SIX YEAR FULL WARRANTY ON SEALED REFRIGERATION PARTS AS LISTED

Any sealed refrigeration system component, as listed below, is warranted to be free from defective materials or workmanship in normal household use during the third through the sixth year from the date of original retail purchase. Viking Range, LLC, warrantor, agrees to repair or replace, at its option, any part which fails or is found to be defective during the warranty period.

**Sealed Refrigeration System Components:** Compressor, Evaporator, Condenser, Connecting Tubing, Dryer/Strainer

### TWELVE YEAR LIMITED WARRANTY ON SEALED REFRIGERATION PARTS AS LISTED

Any sealed refrigeration system component, as listed above, which fails due to defective materials or workmanship in normal household use during the seventh through the twelfth year from the date of original retail purchase will be repaired or replaced, free of charge for the part itself, with the owner paying all other costs, including labor.

## TERMS AND CONDITIONS

This warranty extends to the original purchaser of the product warranted hereunder and to each transferee owner of the product during the term of the warranty and applies to products purchased and located in the United States, Canada, Mexico and the Caribbean (excluding Cuba, Dominican Republic, and Haiti). Products must be purchased in the country where service is requested. If the product or one of its component parts contains a defect or malfunction during the full warranty period after a reasonable number of attempts by the warrantor to remedy the defect or malfunction, the owner is entitled to either a refund or replacement of the product or its component part or parts. Replacement of a component part includes its free installation, except as specified under the limited warranty. Under the terms of this warranty, service must be performed by a factory authorized Viking Range, LLC service agent or representative. Service will be provided during normal business hours, and labor performed at overtime or premium rates shall not be covered by this warranty.

Owner shall be responsible for proper installation, providing reasonable and necessary maintenance, providing proof of purchase upon request, and making the appliance reasonably accessible for service. The return of the Owner Registration Card is not a condition of warranty coverage. You should, however, return the Owner Registration Card so that Viking Range, LLC can contact you should any question of safety arise which could affect you.

This warranty gives you specific legal rights, and you may also have other rights which may vary from jurisdiction to jurisdiction.

**WHAT IS NOT COVERED BY THIS WARRANTY:** This warranty shall not apply to damage resulting from abuse, failure to provide reasonable and necessary maintenance, accident, delivery, negligence, natural disaster, loss of electrical power to the product for any reason, alteration, outdoor use, improper installation, improper operation, or repair or service of the product by anyone other than an authorized Viking Range, LLC service agency or representative. This warranty does not apply to commercial usage.

### LIMITATION OF REMEDIES AND DURATION OF IMPLIED WARRANTY

**OWNER'S SOLE AND EXCLUSIVE REMEDY FOR A CLAIM OF ANY KIND WITH RESPECT TO THIS PRODUCT SHALL BE THE REMEDIES SET FORTH ABOVE. VIKING RANGE, LLC IS NOT RESPONSIBLE FOR CONSEQUENTIAL OR INCIDENTAL DAMAGE, INCLUDING BUT NOT LIMITED TO FOOD OR MEDICINE LOSS, DUE TO PRODUCT FAILURE, WHETHER ARISING OUT OF BREACH OF WARRANTY, BREACH OF CONTRACT OR OTHERWISE.** Some jurisdictions do not allow the exclusion or limitation of incidental or consequential damages, so the above limitation or exclusions may not apply to you. **ANY IMPLIED WARRANTIES OF MERCHANTABILITY OR FITNESS FOR A PARTICULAR PURPOSE APPLICABLE TO THIS PRODUCT ARE LIMITED IN DURATION TO THE PERIOD OF COVERAGE OF THE APPLICABLE EXPRESS WRITTEN LIMITED WARRANTIES SET FORTH ABOVE.** Some states do not allow limitations on how long an implied warranty lasts, so the above limitation may not apply to you.

### WARRANTY SERVICE

To obtain warranty service, contact an authorized Viking Range, LLC service agent, or Viking Range, LLC, 111 Front Street, Greenwood, Mississippi 38930, (888) 845-4641. Provide model and serial number and date of original purchase or closing date for a new construction. For the name of your nearest authorized Viking Range, LLC service agency, call Viking Range, LLC.

**IMPORTANT:** Retain proof of original purchase to establish warranty period.

Specifications subject to change without notice.

Viking Range, LLC  
111 Front Street  
Greenwood, Mississippi 38930 USA  
(662) 455-1200

For product information,  
call 1-888-(845-4641)  
or visit our web site at [vikingrange.com](http://vikingrange.com) in the US  
or [brigade.ca](http://brigade.ca) in Canada